

MATERIAL KEY LEGEND

- 1 RECONSTITUTED SLATE ROOF FINISHES - GREY
- 2 WHITE UPVC FASCIAS, SOFFITES AND BARGEBOARDS WITH BLACK RAINWATER GOODS
- 3 ANTHRACITE GREY UPVC DOUBLE GLAZED WINDOWS AND REAR DOOR UNITS
- 4 THRU COLOURED RENDER SYSTEM AS MAIN FINISHES - COLOUR TO SUIT PLOTS
- 5 GRP PORCH CANOPY OVER
- 6 FACING BRICKWORK UP TO DPC LEVEL
- 7 GRP COMPOSITE FRONT ENTRANCE DOORS COLOUR: TBC
- 8 ANTHRACITE GREY FIBRE CEMENT HORIZONTAL BOARDING DETAIL
- 9 LOCATION OF BIRD BOX - REFER TO ECOLOGISTS REPORT
- 10 LOCATION OF BAT BOX - REFER TO ECOLOGISTS REPORT
- 11 PV PANELS - EXACT LOCATIONS TO SUIT DWELLINGS ORIENTATION TO SOUTH

Do not scale from this drawing. The users of this drawing shall check all dimensions and details against the drawings and specifications issued by the Design. This drawing is copyright. It must not be reproduced, stored in a retrieval system or used in any form without prior permission of LeTrucco Design.

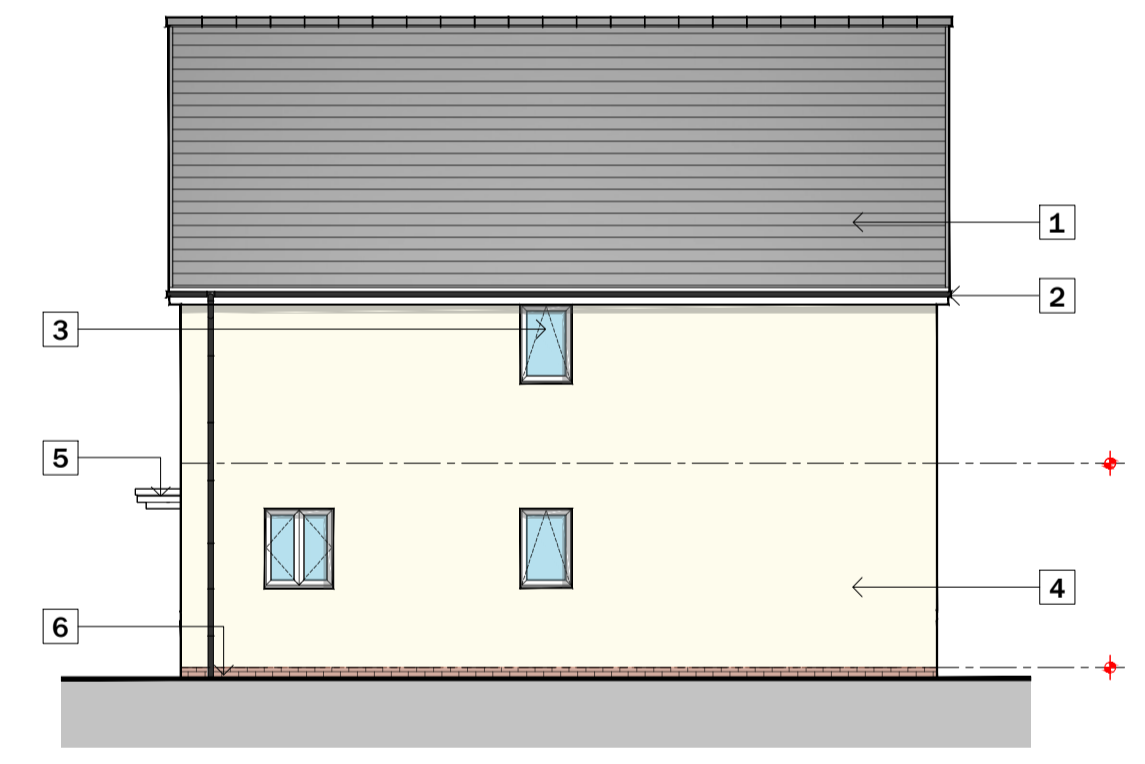
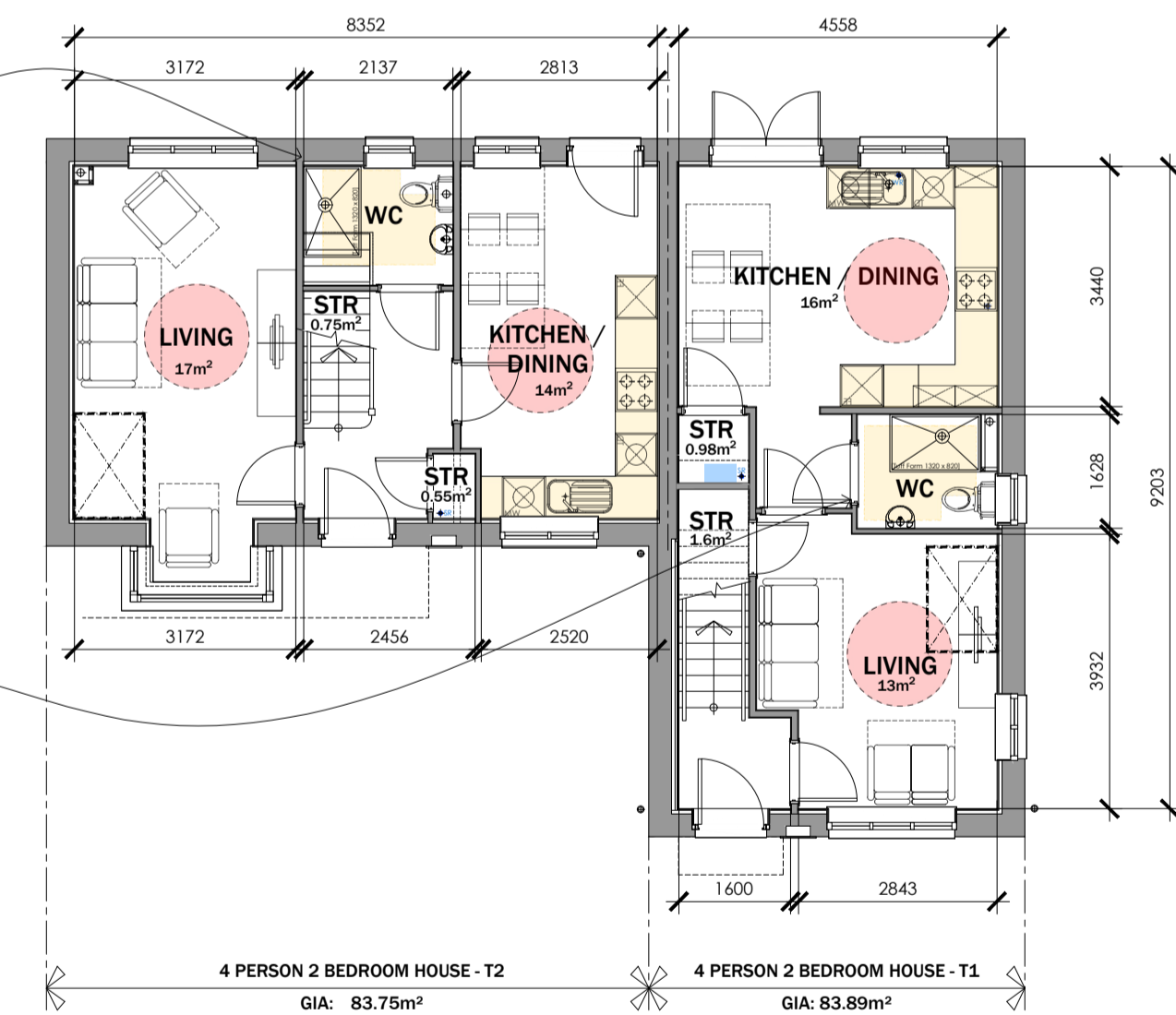
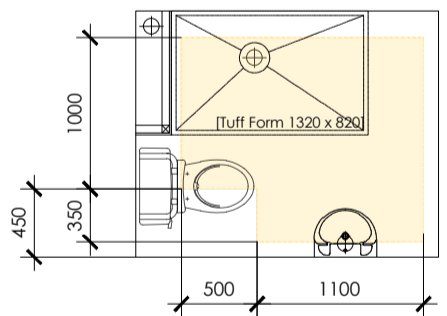
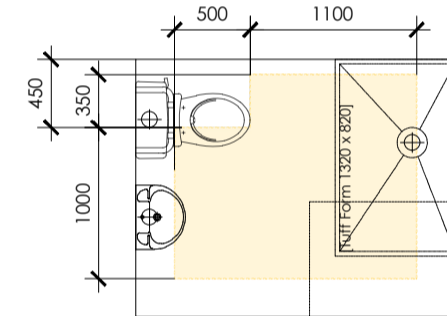
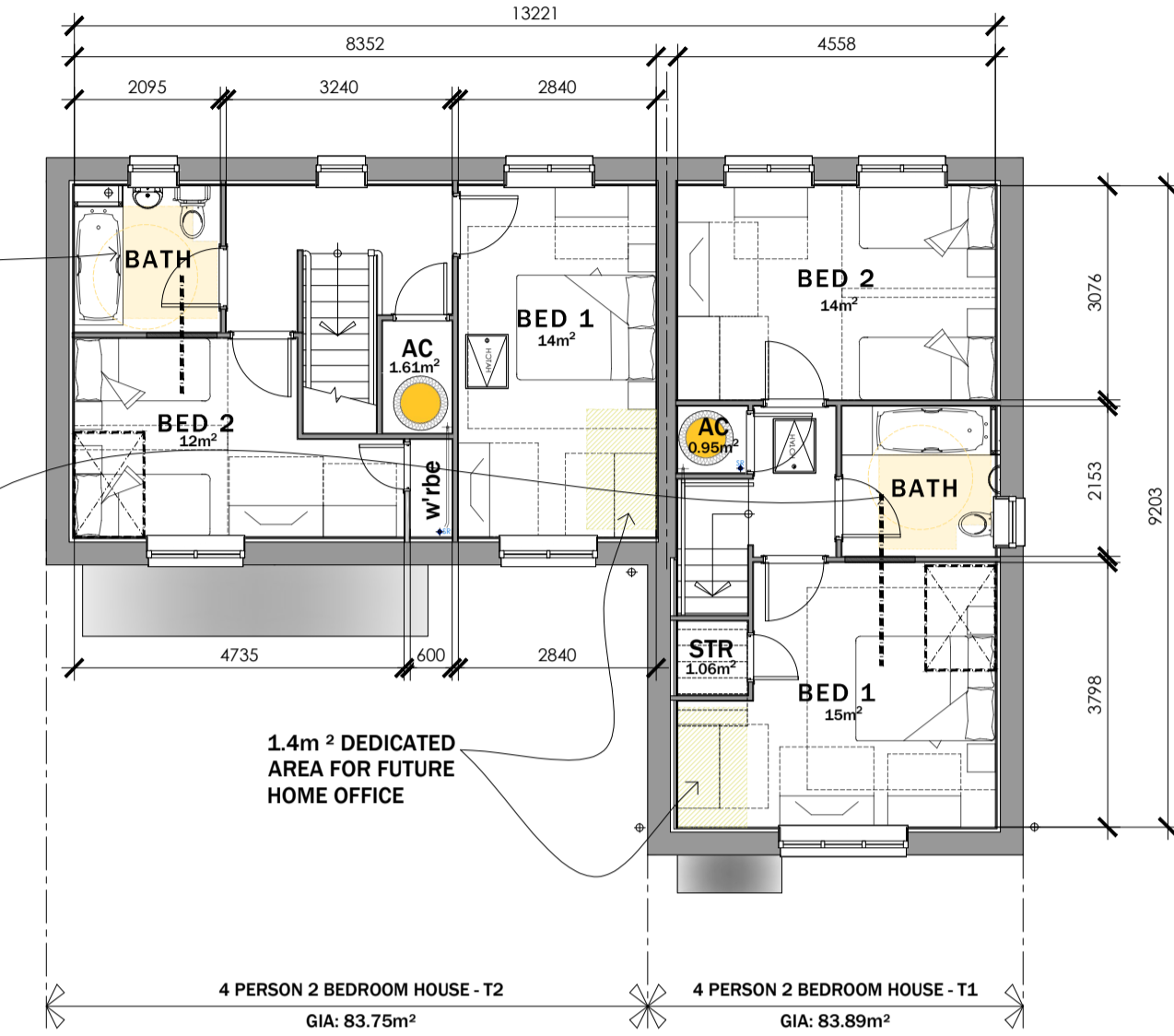
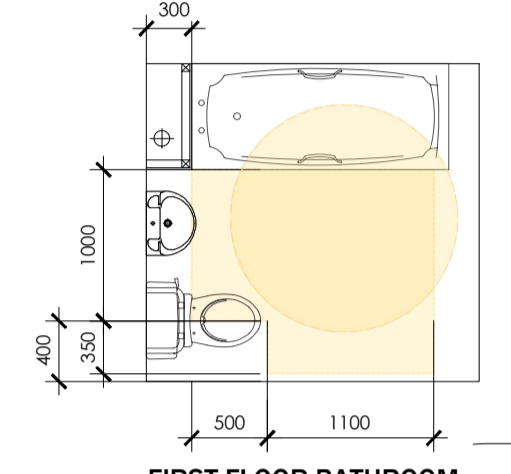
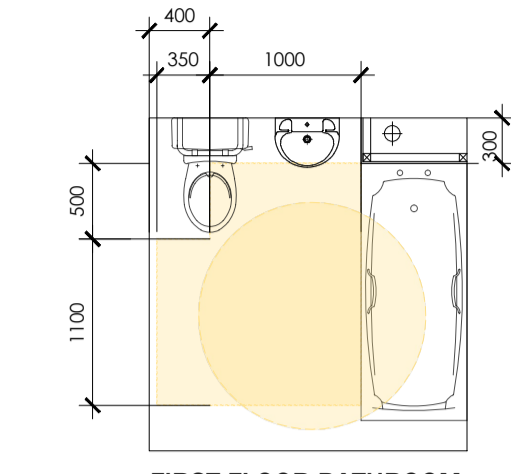

STORAGE SCHEDULE:

4P2B HOUSE TYPE 1

GROUND FLOOR:
STORE: 0.98M²
WC/STAIRS: 1.60M²

FIRST FLOOR:
AC: 0.95M²
STORE: 1.06M²

TOTAL STORAGE PROVIDED - 4.59M²

TOTAL STORAGE REQUIRED - 2.5M²

TOTAL STORAGE EXCESS - 2.09M²

4P 2B HOUSE TYPES
Plots 3 - 4
G.I.A = 83.89m² / 902.98 ft²
83.75M² / 901.48 ft²

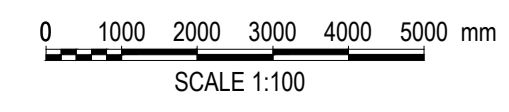

Revisions
Drawing updated along with plot numbers to suit revised site layout

Drawing No	Revision	Scale	Date	Checked
LT2413.04.101	A	1:100 @ A1	Nov 24	KWL
Job Title	4P 2B House Types - 3 - 4			
Client	Wellspring / Bron Afon			
Job Title	Traston Lane, Newport			

Drawing Purpose
PLANNING

LeTrucco
ARCHITECTURE

Suite 7, 35 Stow Park Circle
Newport, NP20 4HF

Tel: 07710390800 / 07710390801
info@letruccodesign.co.uk
www.letruccodesign.co.uk