

MATERIAL KEY LEGEND

- 1 RECONSTITUTED SLATE ROOF FINISHES - GREY
- 2 WHITE UPVC FASCIAS, SOFFITES AND BARGEBOARDS WITH BLACK RAINWATER GOODS
- 3 ANTHRACITE GREY UPVC DOUBLE GLAZED WINDOWS AND REAR DOOR UNITS
- 4 THRU COLOURED RENDER SYSTEM AS MAIN FINISHES - COLOUR TO SUIT PLOTS
- 5 GRP PORCH CANOPY OVER
- 6 FACING BRICKWORK UP TO DPC LEVEL
- 7 GRP COMPOSITE FRONT ENTRANCE DOORS COLOUR: TBC
- 8 ANTHRACITE GREY FIBRE CEMENT HORIZONTAL BOARDING DETAIL
- 9 LOCATION OF BIRD BOX - REFER TO ECOLOGISTS REPORT
- 10 LOCATION OF BAT BOX - REFER TO ECOLOGISTS REPORT
- 11 PV PANELS - EXACT LOCATIONS TO SUIT DWELLINGS ORIENTATION TO SOUTH

Do not scale from this drawing. The users of this drawing shall check all dimensions and details against the drawings and specifications and shall be responsible for any omissions to LeTrucco Design. This drawing is copyright. It must not be reproduced, stored in a retrieval system or used in any form without prior permission of LeTrucco Design.

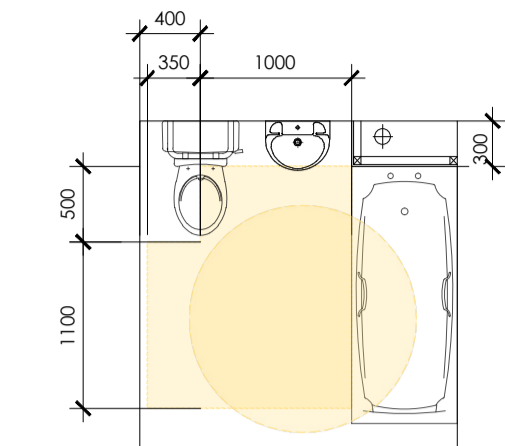

FIRST FLOOR BATHROOM [LTH CRITERION 14]

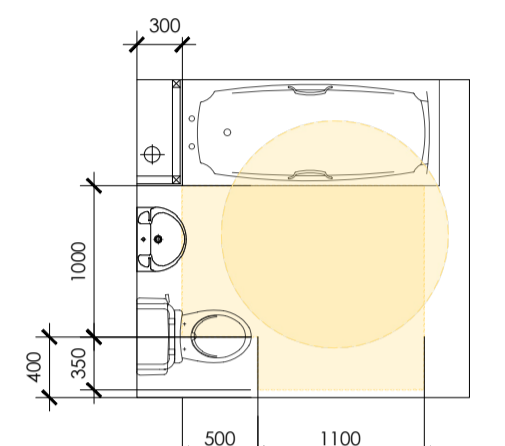

FIRST FLOOR BATHROOM [LTH CRITERION 14]

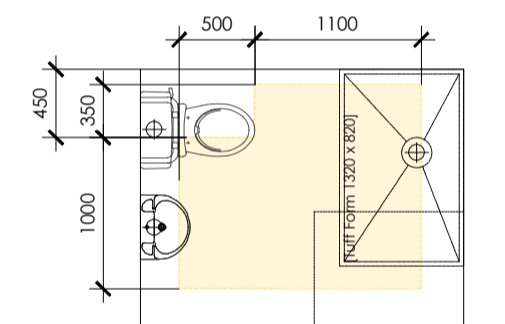

GROUND FLOOR ACCESSIBLE WC [LTH CRITERION 14]

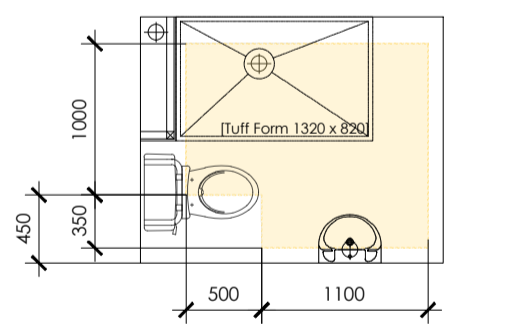

GROUND FLOOR ACCESSIBLE WC [LTH CRITERION 14]

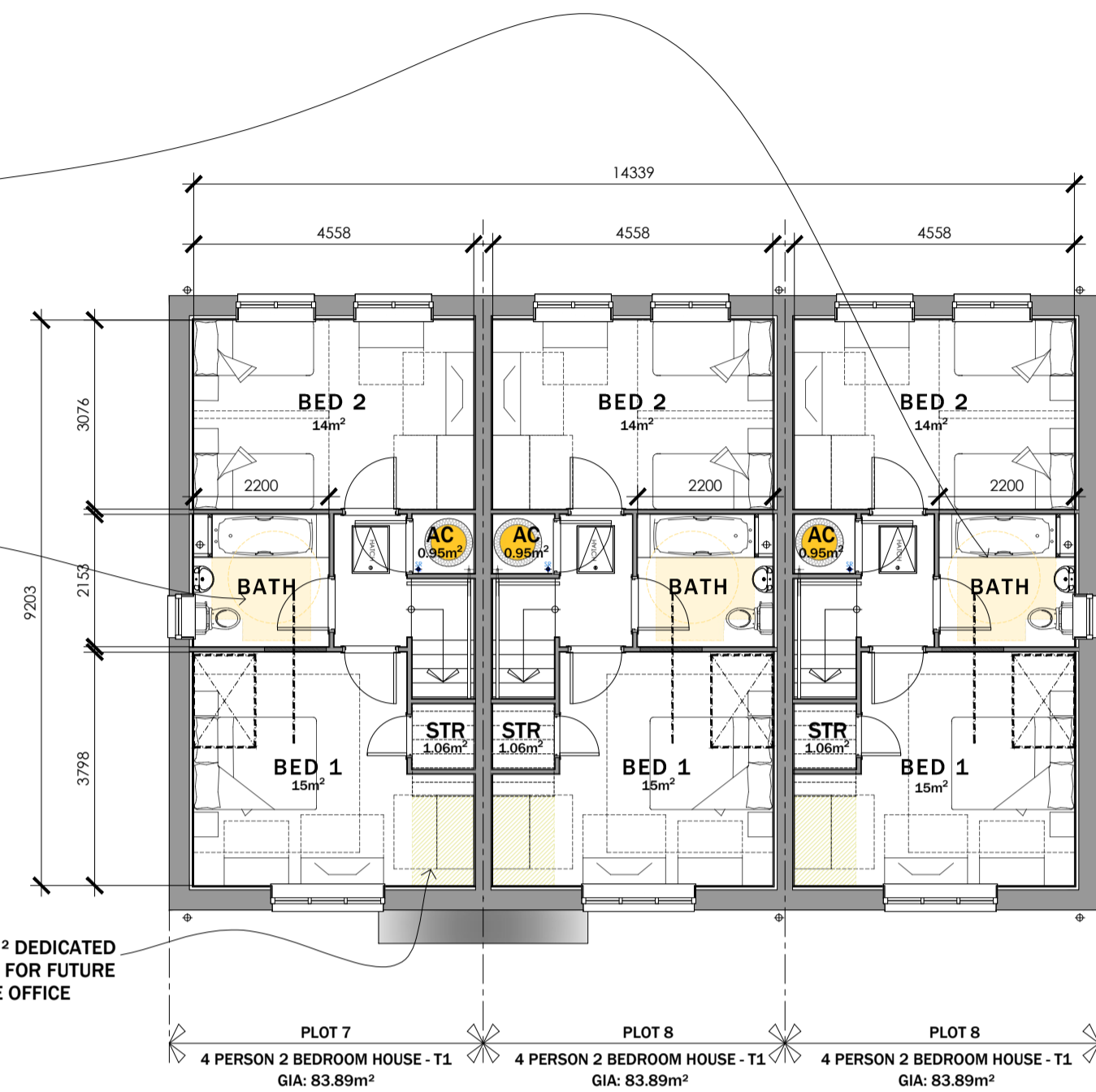

FIRST FLOOR PLAN

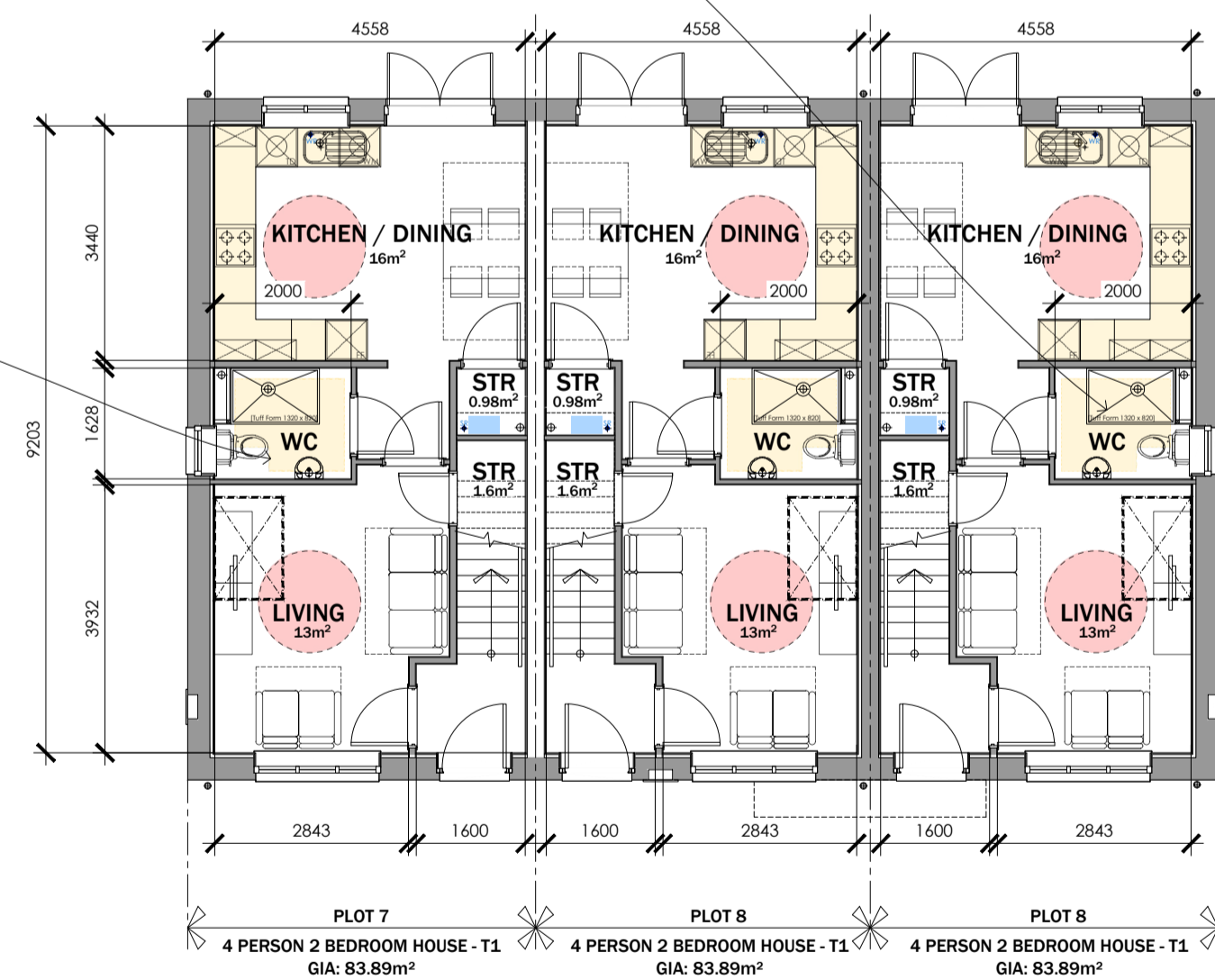

GROUND FLOOR PLAN

STORAGE SCHEDULE:

4P2B HOUSE TYPE 1  
 GROUND FLOOR:  
 STORE: 0.98M<sup>2</sup>  
 U/S STAIRS: 1.60M<sup>2</sup>  
 FIRST FLOOR:  
 AC: 0.95M<sup>2</sup>  
 STORE: 1.06M<sup>2</sup>

TOTAL STORAGE PROVIDED - 4.59M<sup>2</sup>  
 TOTAL STORAGE REQUIRED - 2.5M<sup>2</sup>  
 TOTAL STORAGE EXCESS - 2.09M<sup>2</sup>



FRONT ELEVATION

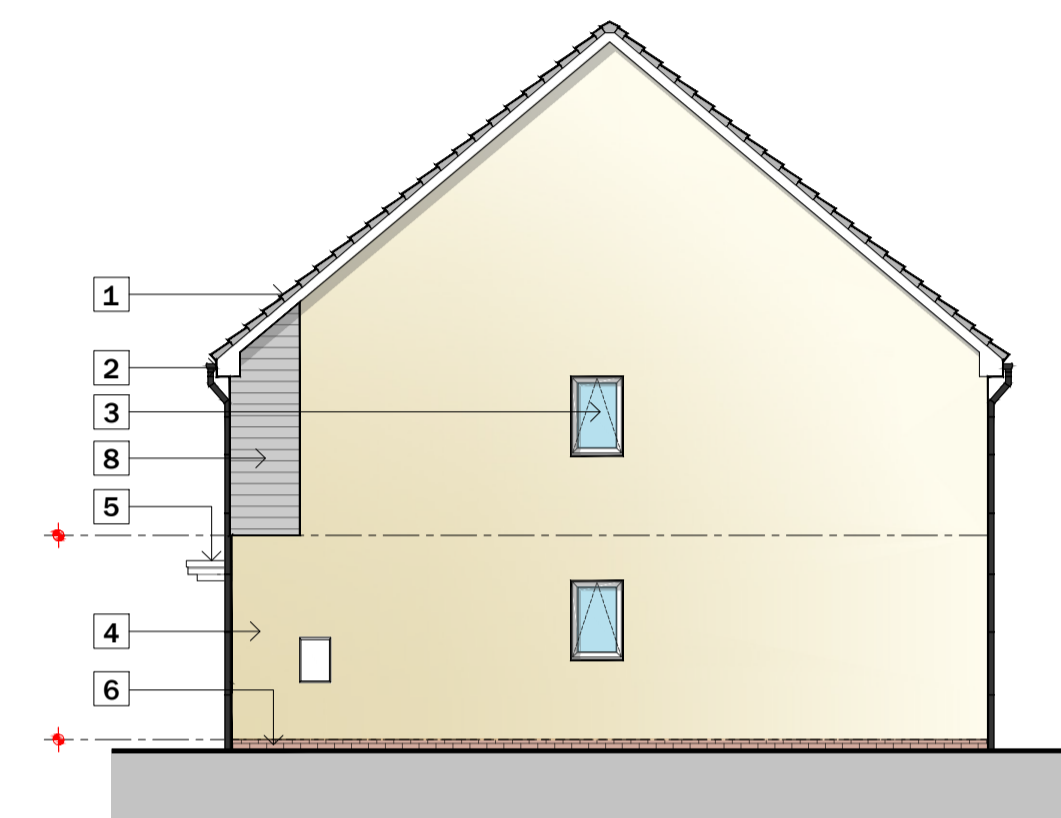

SIDE ELEVATION



REAR ELEVATION

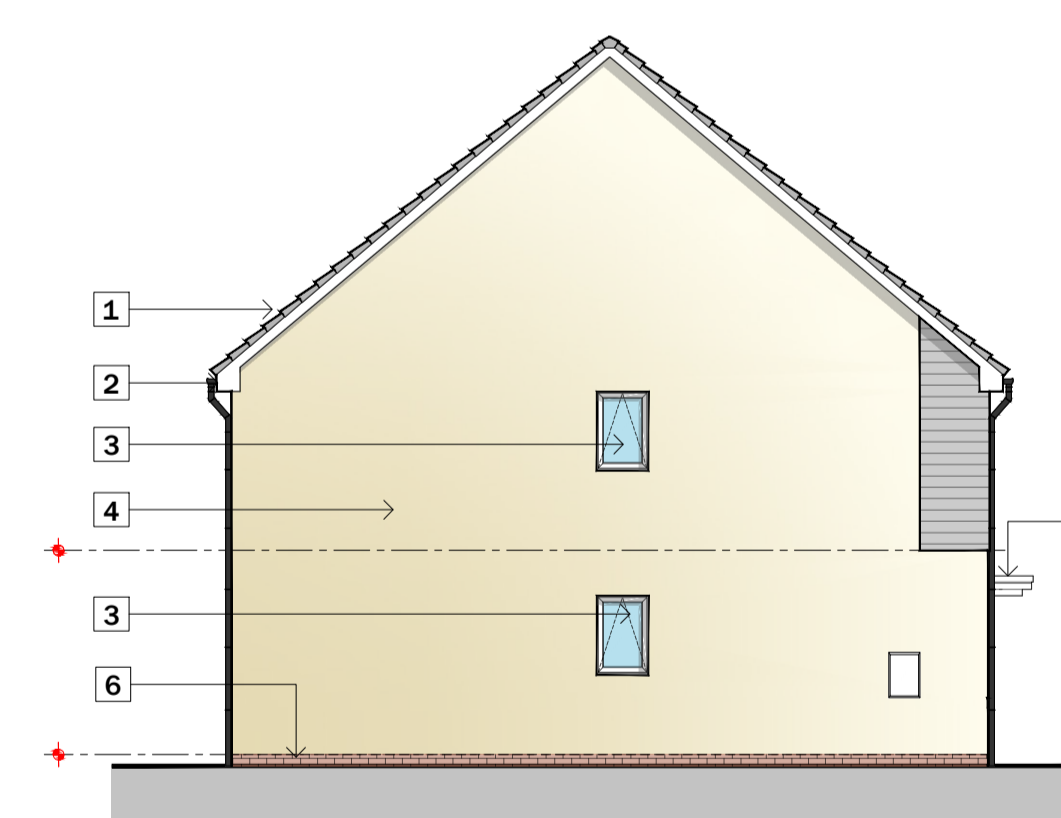

SIDE ELEVATION

4P 2B HOUSE TYPE 1 + 2  
 Plots 20 - 22

G.I.A = 83.89m<sup>2</sup> / 902.98 ft<sup>2</sup>  
 83.75M<sup>2</sup> / 901.48 ft<sup>2</sup>

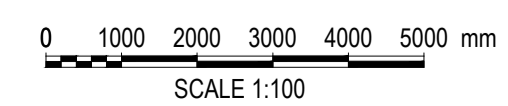

Revisions  
 Rev.A Oct 25  
 Rev.B Oct 25  
 Rev.C Oct 25  
 Rev.D Oct 25  
 Rev.E Oct 25  
 Rev.F Oct 25  
 Rev.G Oct 25  
 Rev.H Oct 25  
 Rev.I Oct 25  
 Rev.J Oct 25  
 Rev.K Oct 25  
 Rev.L Oct 25  
 Rev.M Oct 25  
 Rev.N Oct 25  
 Rev.O Oct 25  
 Rev.P Oct 25  
 Rev.Q Oct 25  
 Rev.R Oct 25  
 Rev.S Oct 25  
 Rev.T Oct 25  
 Rev.U Oct 25  
 Rev.V Oct 25  
 Rev.W Oct 25  
 Rev.X Oct 25  
 Rev.Y Oct 25  
 Rev.Z Oct 25

Revision	Scale	Date	Checked
A	1:100 @ A1	Nov 24	KWL

Drawing Purpose  
 PLANNING

Client  
 Wellspring / Bron Afon  
 Job Title  
 4P 2B House Types - 20 - 22  
 Traston Lane, Newport

**LeTruccodesign**  
 ARCHITECTURE  
 Suite 7, 35 Stow Park Circle  
 Newport, NP20 4HF  
 Tel: 07710390800 / 07710390801  
 info@letruccodesign.co.uk  
 www.letruccodesign.co.uk