

Cambrian Road – Replacement Windows - to be read in conjunction with Window Schedule.

Project Summary



1. Ali Vertical sliders with sash horn
Quantity: 4
Supply & Fit - Remove & replace

Aluminium
Vertical Slider

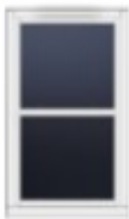

2. Ali Vertical sliders with sash horn
Quantity: 4
Supply & Fit - Remove & replace

Aluminium
Vertical Slider



3. W12
Quantity: 1
Supply & Fit - Remove & replace

Spectus Elite 70
Casement

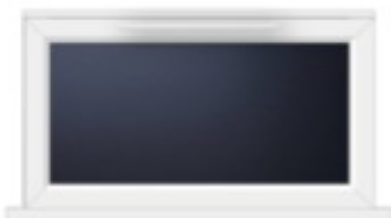

4. w13
Quantity: 1
Supply & Fit - Remove & replace

Spectus Elite 70
Casement



5. w09
Quantity: 1
Supply & Fit - Remove & replace

Spectus Elite 70
Casement



6. w08
Quantity: 1
Supply & Fit - Remove & replace

Spectus Elite 70
Casement

See details below...

Front Elevation – Second Floor – w1, 2a & 2b and 3. Graphite Grey Aluminium with Horns

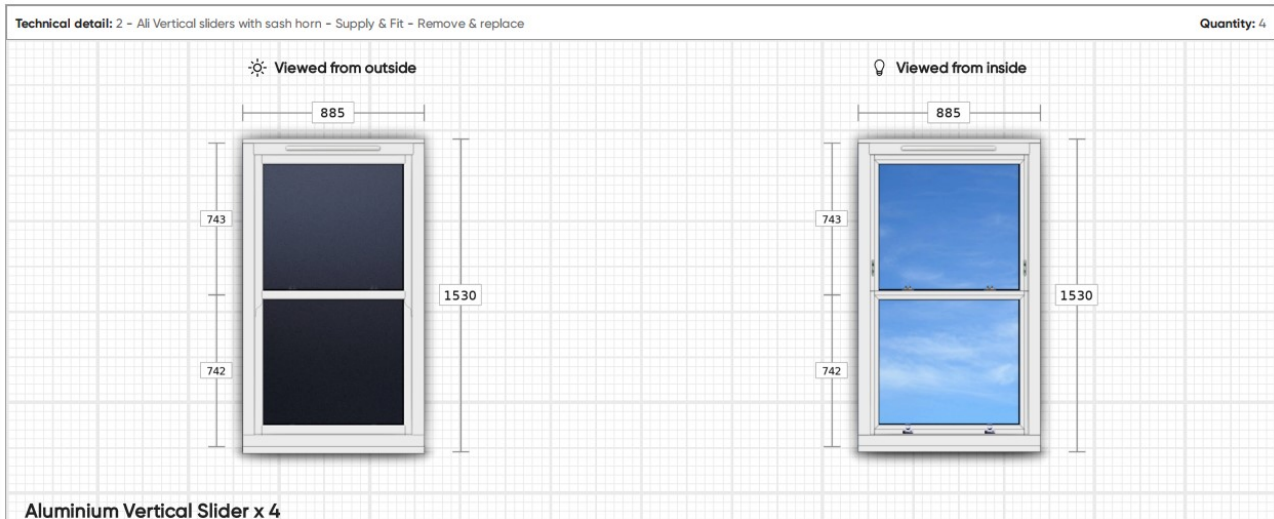

Front Elevation – First Floor – w4, 5a & 5b and 6. Graphite Grey Aluminium with Horns

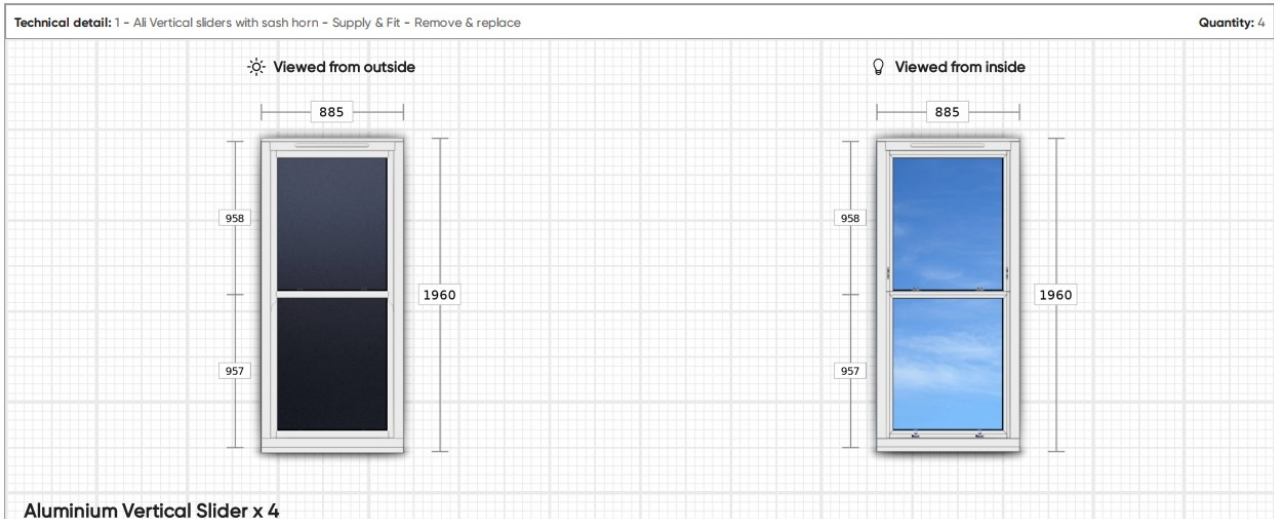

Detail and Sections below..

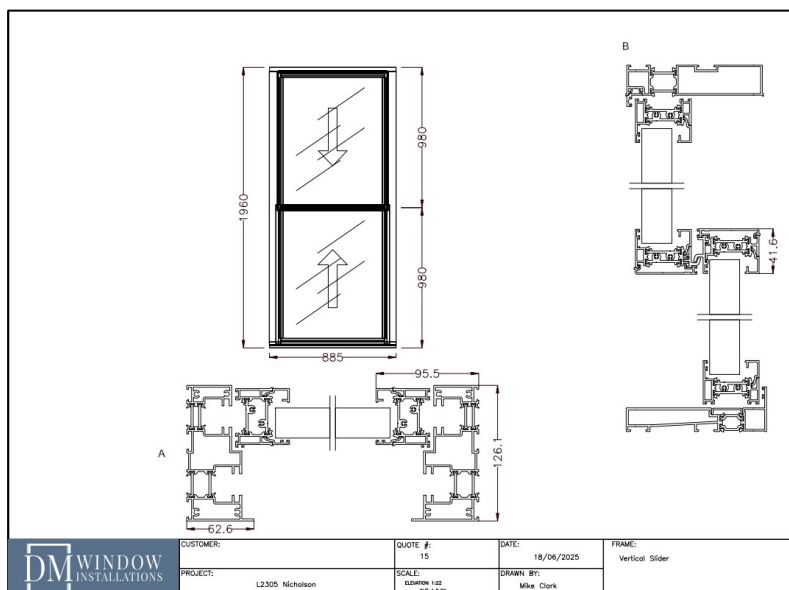

Detail of Horns below...

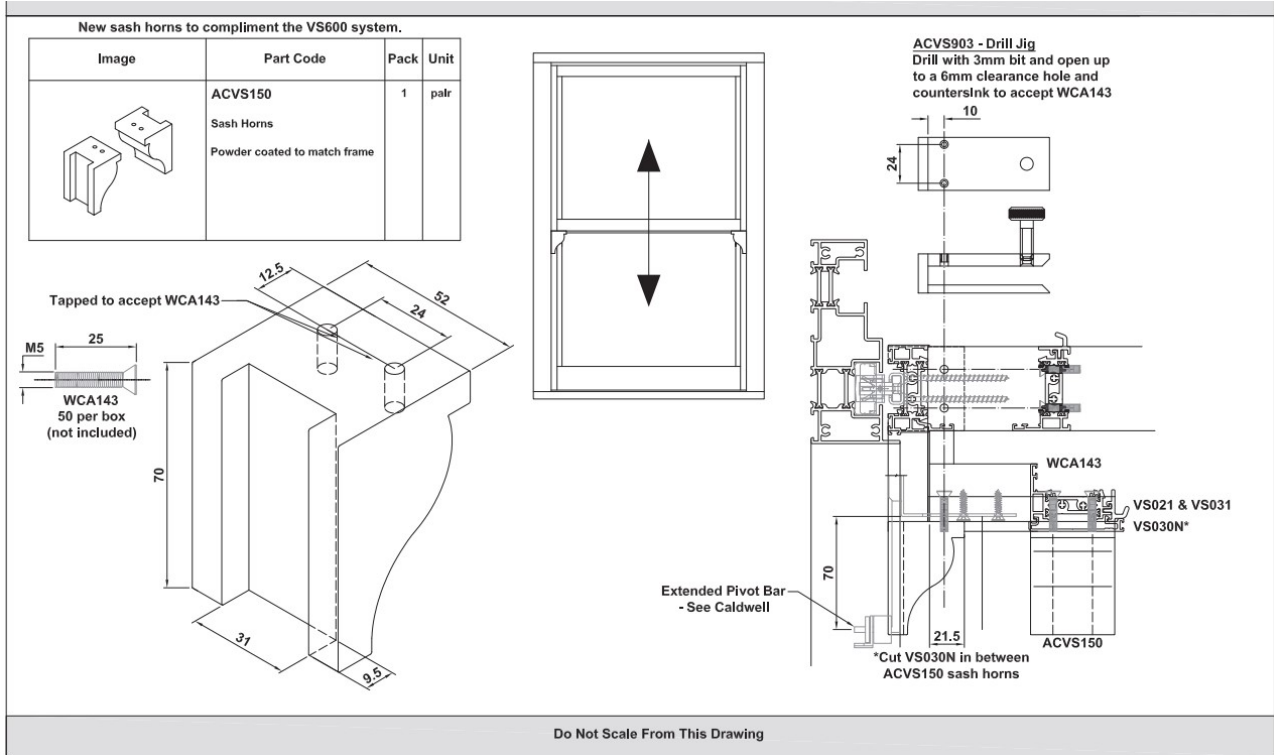

East Courtyard Elevation – Second Floor w8 - Smooth White uPVC.

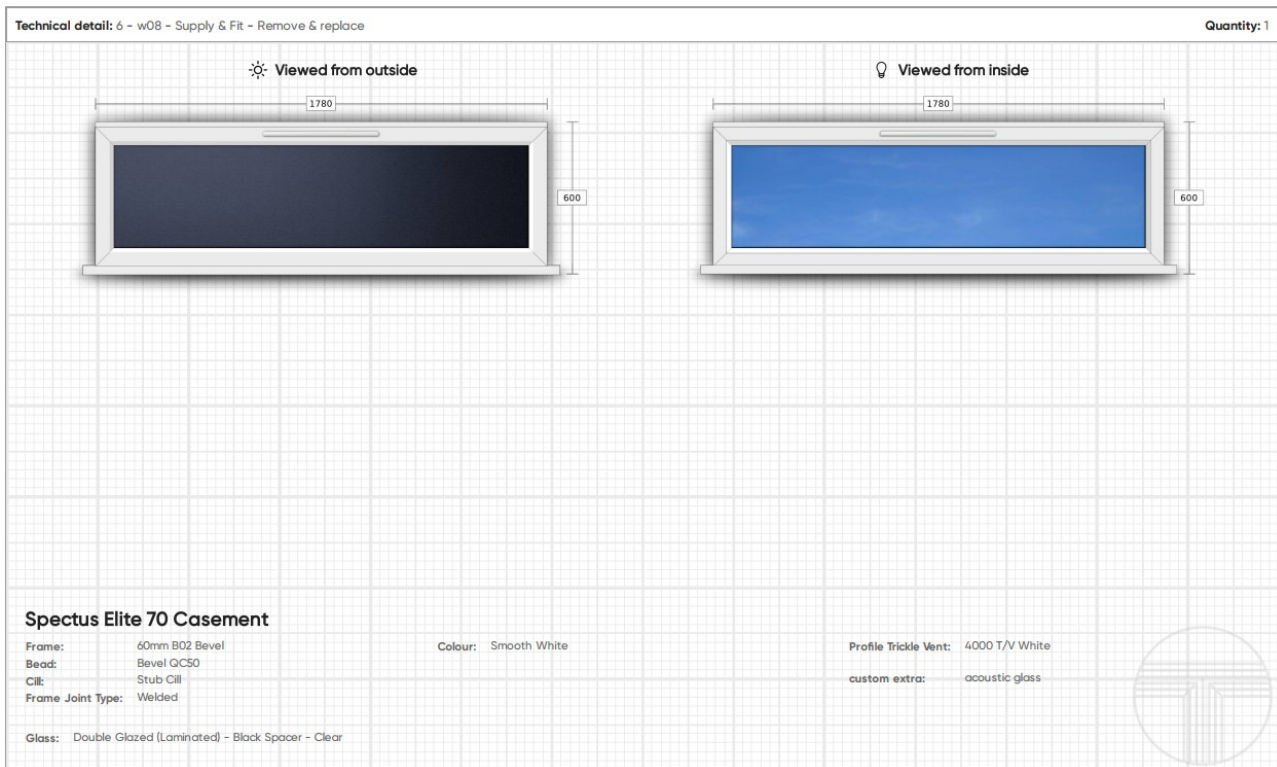

To match existing white Upvc windows in Courtyard, and in the buildings, adjoining the Courtyard.

East Courtyard Elevation – Second Floor w9 - Smooth White Upvc.



South Courtyard Elevation – Second Floor w10 and 11 - Existing Smooth White uPVC – Replacement double glazed units with acoustic glass and trickle vents. Frosted glass.

South Courtyard Elevation – First Floor w12 - Smooth White uPVC

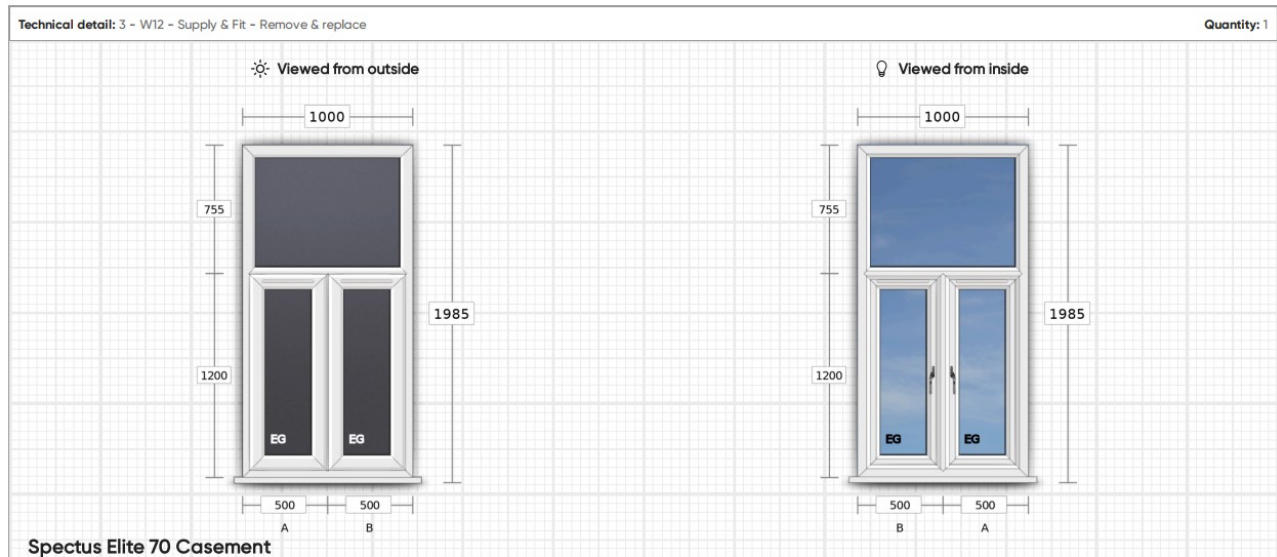

South Courtyard Elevation – First Floor w13 - Smooth White uPVC

☀ Viewed from outside

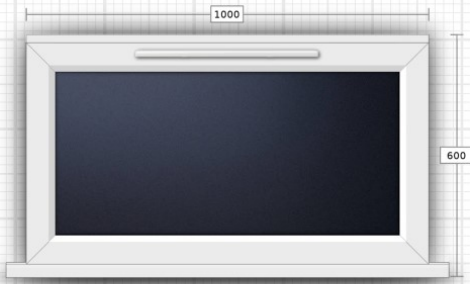

☁ Viewed from inside



Spectus Elite 70 Casement