

Refuse Truck (waste) - Left In



Refuse Truck (waste) - Right In



Notes

Based on topographical survey and proposed layout details provided by applicant.

Refuse vehicle specification taken from Newport City Council's Waste Storage and Collection Supplementary Planning Guidance; January 2020

Vehicle details:

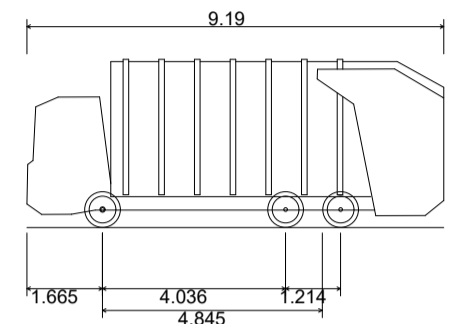

Phoenix 2 (NCC Spec)
Overall Length 9.190m
Overall Width 2.250m
Overall Body Height 3.707m
Min Body Ground Clearance 0.260m
Track Width 2.250m
Lock to lock time 4.00s
Kerb to Kerb Turning Radius 7.850m

Refuse Truck (waste) - Turn & Left In



Refuse Truck (waste) - Right Out



Rev	By	Chkd	Apprvd	Date	Description

Client

Mr A Brown

Project

St Paul's Church
Commercial Street, Newport

Drawing

Residential Waste
Vehicle Tracking

Drawn by: JH Date: 09.01.2025

Checked by: JH Date: 09.01.2025

Approved by: JH Date: 09.01.2025

Drawing No. 2501DWG01 Revision

Drawing Scale: 1:200 @ A1