

- Highway Note**
- Overall highway construction to be 450 mm minimum thickness where solid are found to be most susceptible
 - Prior to laying sub-base materials the formation shall be sprayed with an approved weed killer
 - The CRB of the compacted carrying layer shall be at least 15%
 - Sub-base materials shall be approved and designed in accordance with Chapter 5 of the Traffic Signs Regulations and General Directions 2011.
 - Before works commence on site the road marking scheme must be approved by the proper officer.
 - DO NOT** scale from drawing. Use dimensions provided.
 - All precast items shall be precast manufacturer.

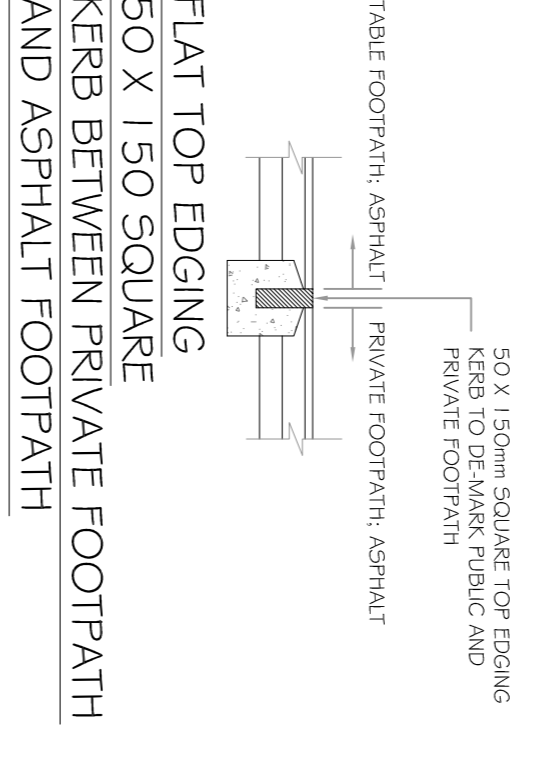
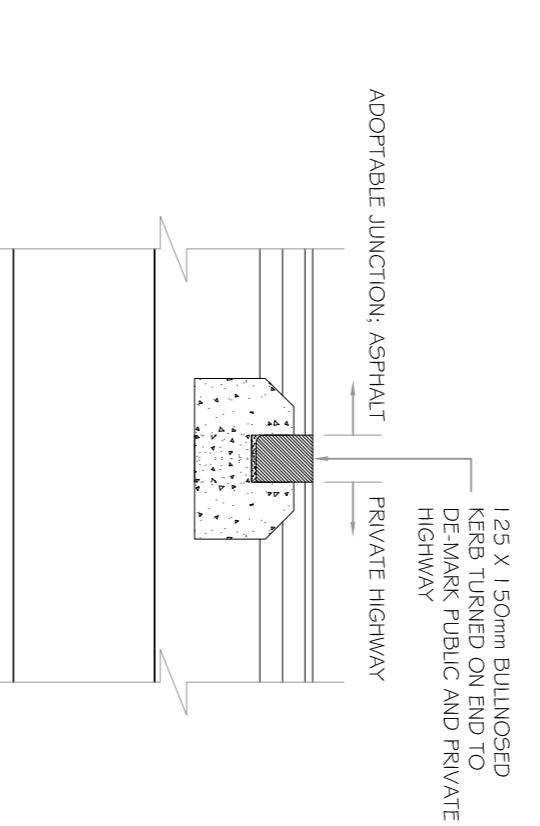
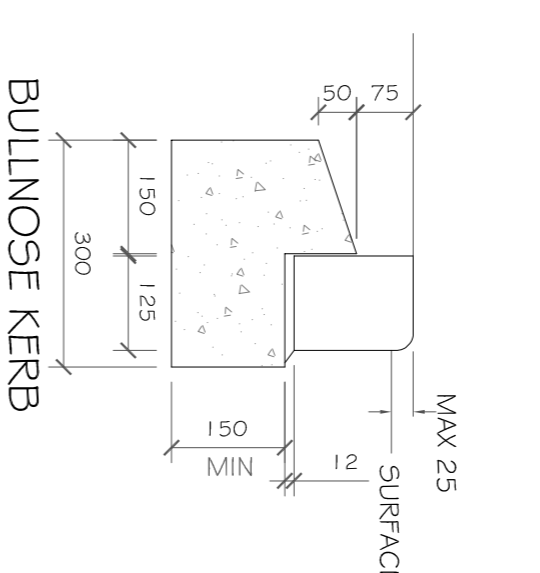
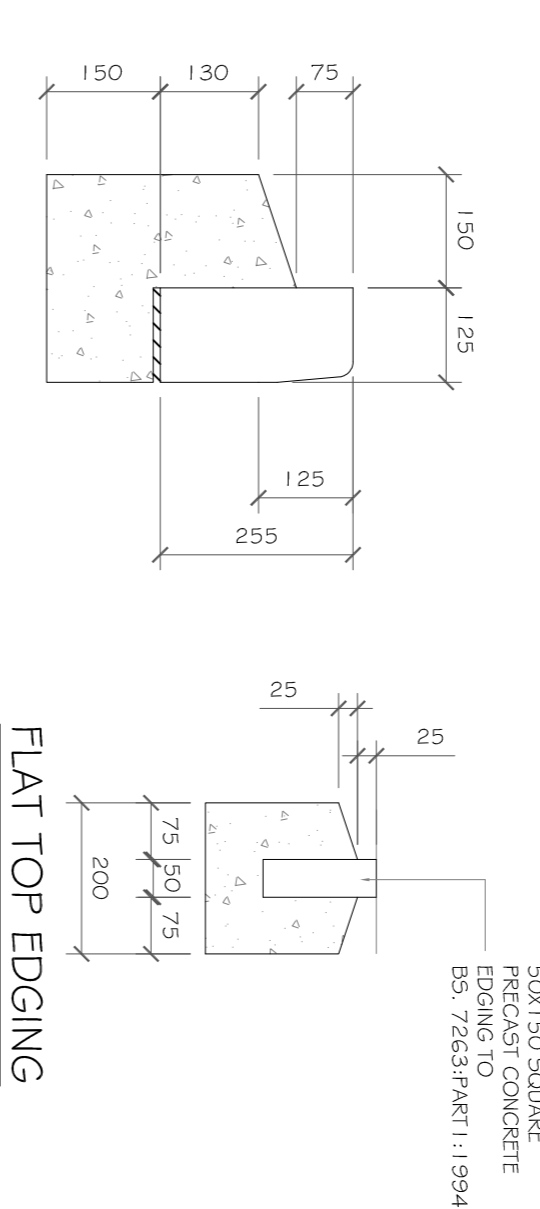

- NOTES**
- ALL DIMENSIONS ARE IN MILLIMETERS.
 - ALL PRECAST CONCRETE ITEMS SHALL BE PRECAST MANUFACTURED
 - BN KERBS TO BE PROVIDED TO FRONT AND BACK OF ALL VEHICLE CROSS OVERS.
 - ALL KERBS TO BE HB2 WITH ASSOCIATED TRANSITION KERBS AT PEDESTRIAN CROSSING POINTS
 - EF FOOTPATH EDGINGS TO BE PROVIDED TO REAR OF ALL FOOTWAYS
 - WHERE KERBS ARE TO BE Laid AGAINST EXISTING CARRIAGEWAY WHICH IS NOT TO BE SURFACED, THE GAP BETWEEN THE CARRIAGEWAY AND KERB SHALL BE DEALT WITH AS FOLLOWS:
A) GAPS LESS THAN 25mm WIDE - CLEAN OUT TO A MINIMUM OF 20mm DEEP AND SEAL TO CAUSE 100% OF THE SPECIFICATION FOR HIGHWAY WORKS.
B) GAPS MORE THAN 25mm WIDE - CLEAN OUT TO A MINIMUM OF 50mm DEEP AND FILL WITH FINE COAD ASPHALT WELL COMPACTED.

TACTILE PAVING

TACTILE PAVING TO BE BUFF COLOUR 400mm x 40mm (6 sided) TO BS 7263 PART 1, 1994 (A1) DIRECTION OF TACTILE PAVING TO BE ORIENTATED IN DIRECTION OF PEDESTRIAN FLOW

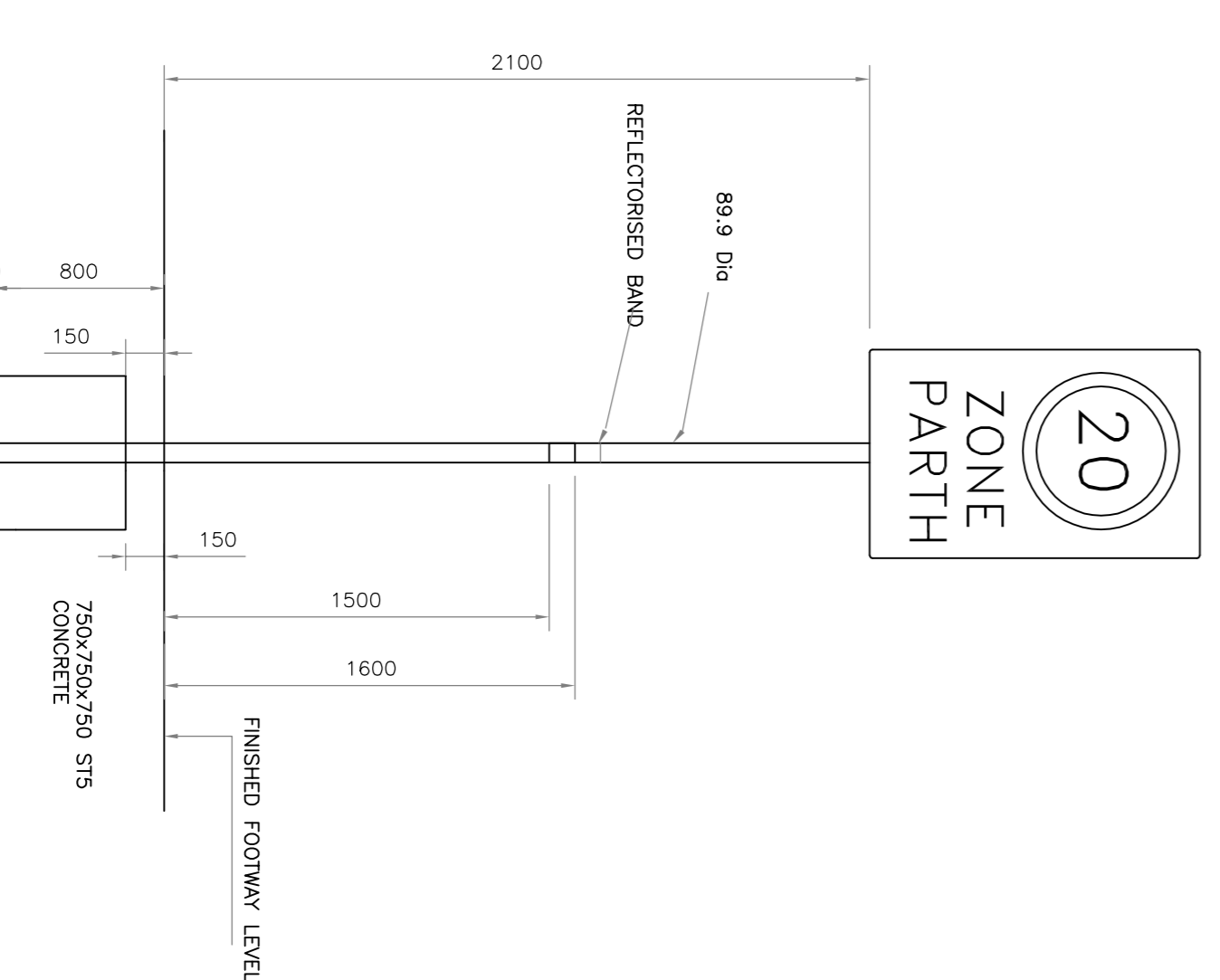
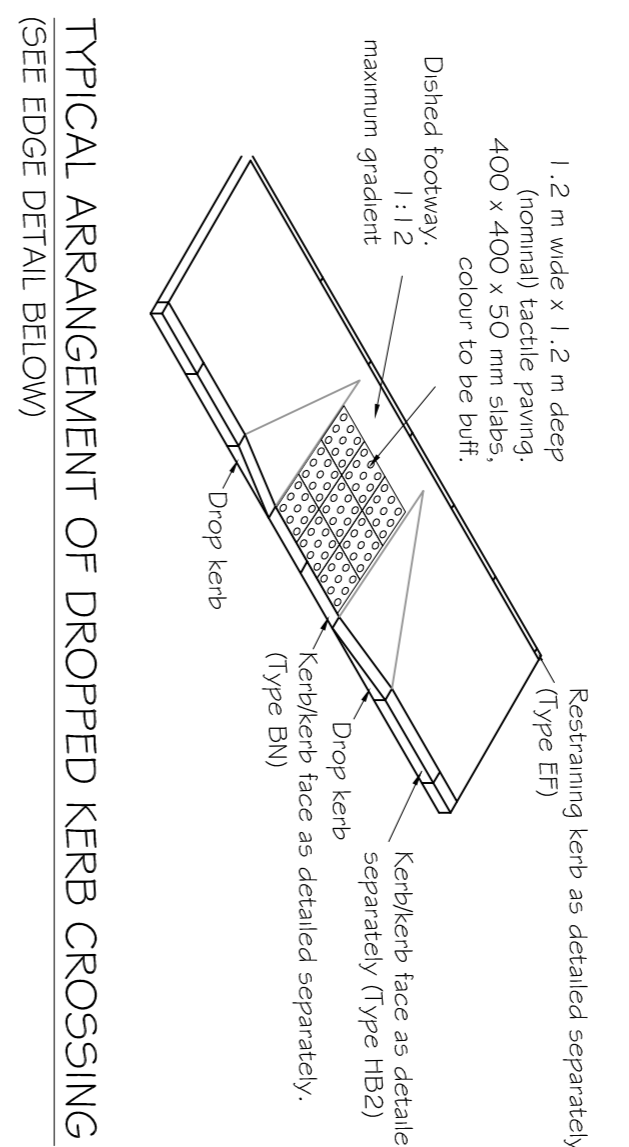
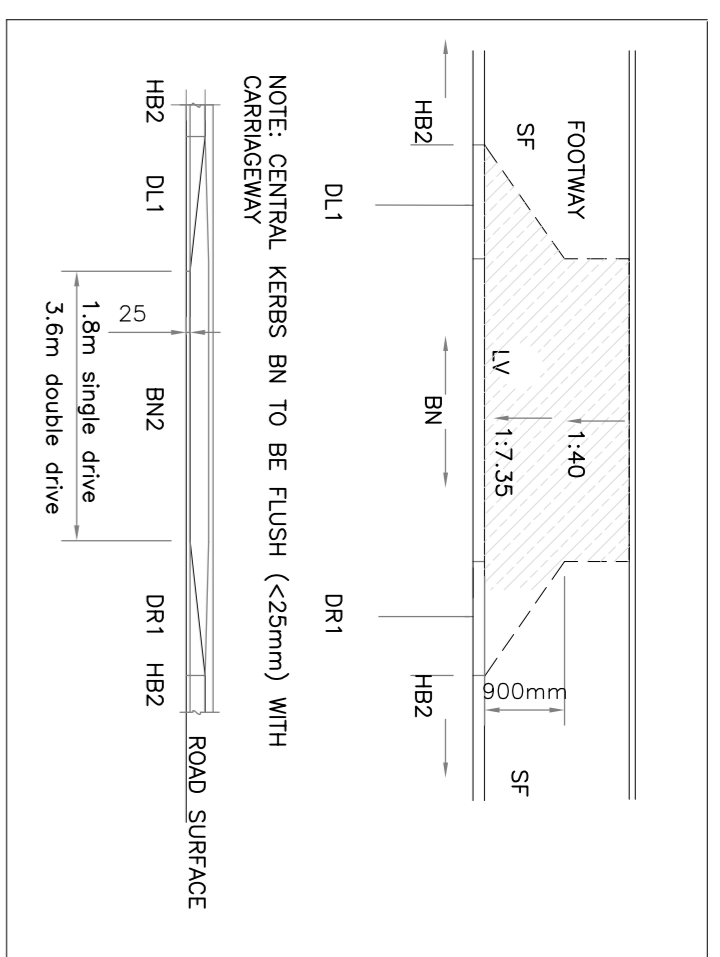
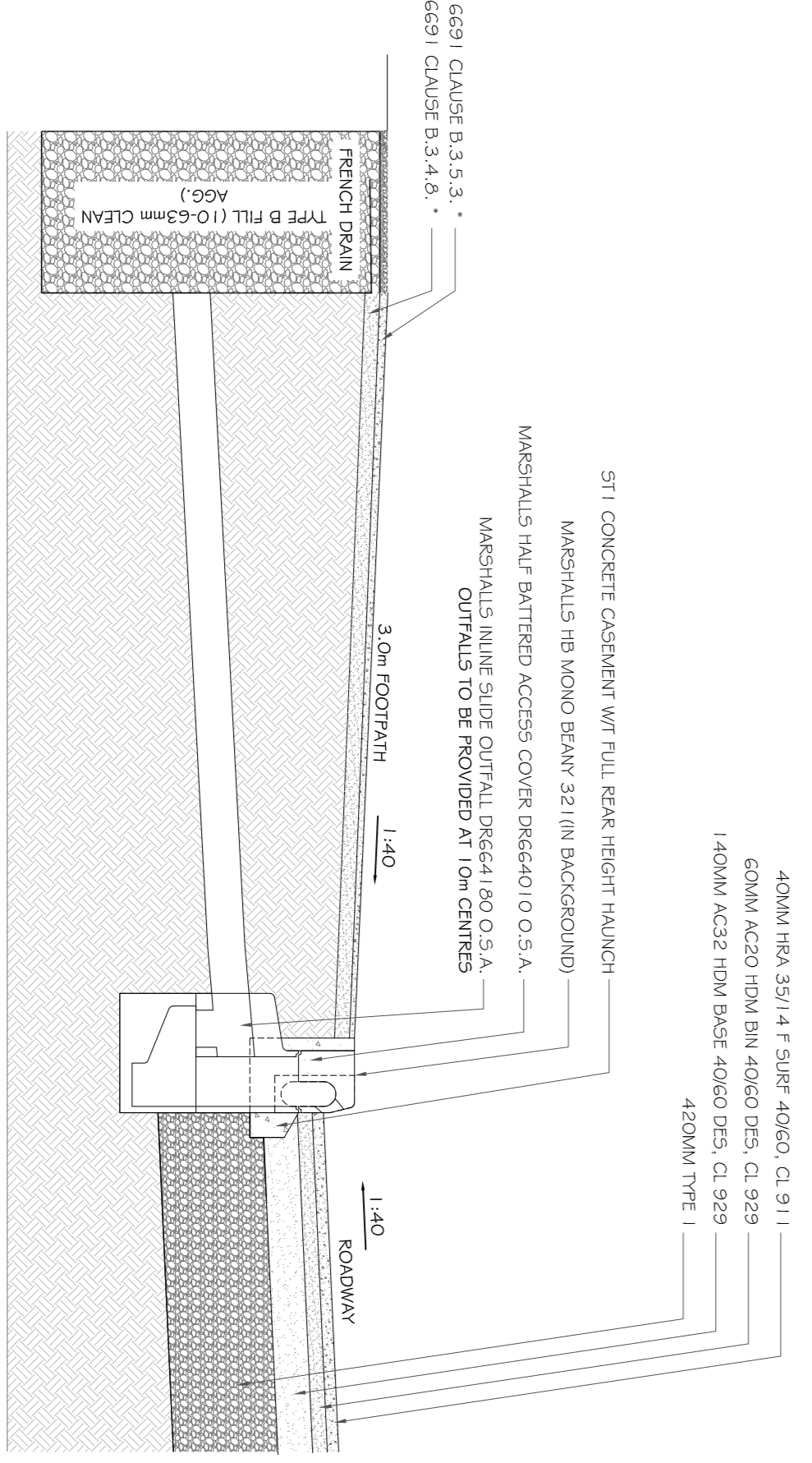

- General Notes :**
- Do not scale from this drawing.
 - All dimensions are in millimetres.
 - All levels are in metres relative to datum.
 - All dimensions stated are to be confirmed on site prior to commencement of any works and any discrepancies found are to be reported to Steve Morgan Associates Limited immediately.

Client	Steve Morgan Associates
Project Description	PROPOSED HOUSING DEVELOPMENT, HERBERT ROAD NEWPORT
Drawing Title	PROPOSED PHASE 1 HIGHWAYS CONSTRUCTION DETAILS
Drawn	TDJ
Checked	TDJ
Drawing Status	SECTION 38
Scales	AS STATED @ A1
Project Number	1155090
Drawing Number	704
Rev	A

STEVE MORGAN ASSOCIATES
CONSULTING ENGINEERS
9 Glyn Park Road Newport NP23 5PB
01690 733333
email: engineers@smalimited.co.uk Web: smalimited.co.uk