

Elevation

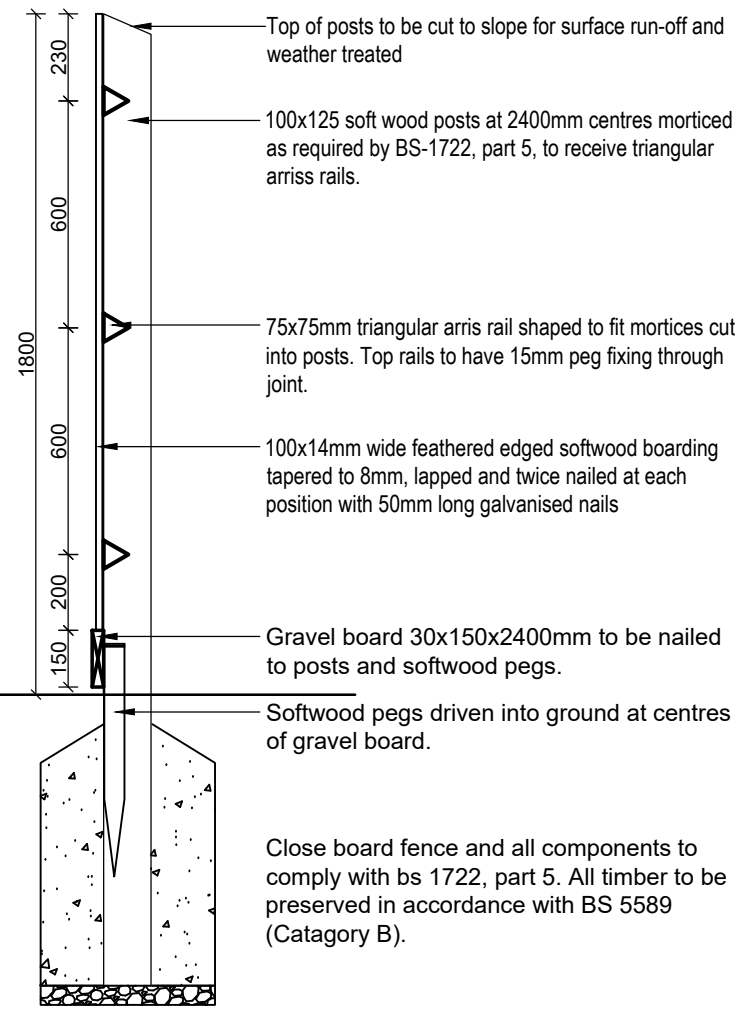

Section A-A

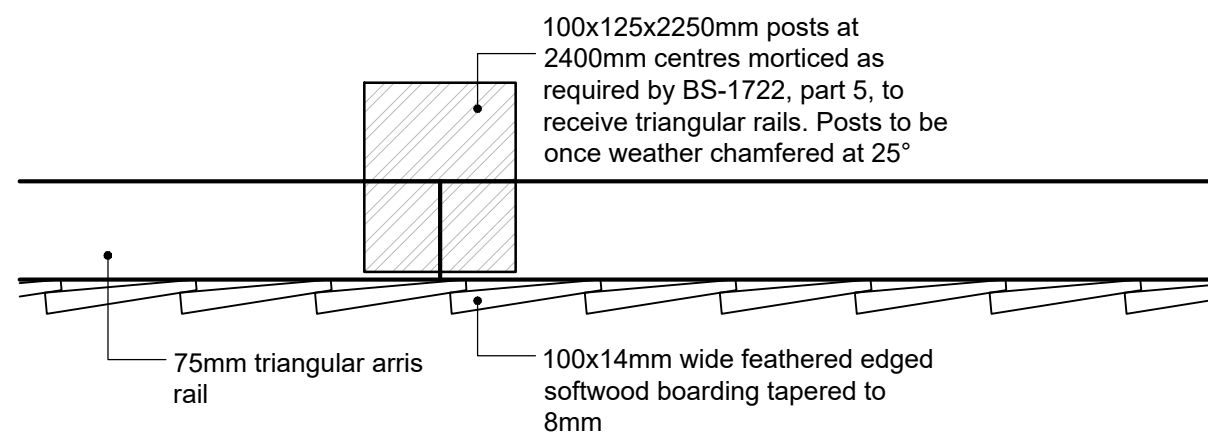

Section Detail

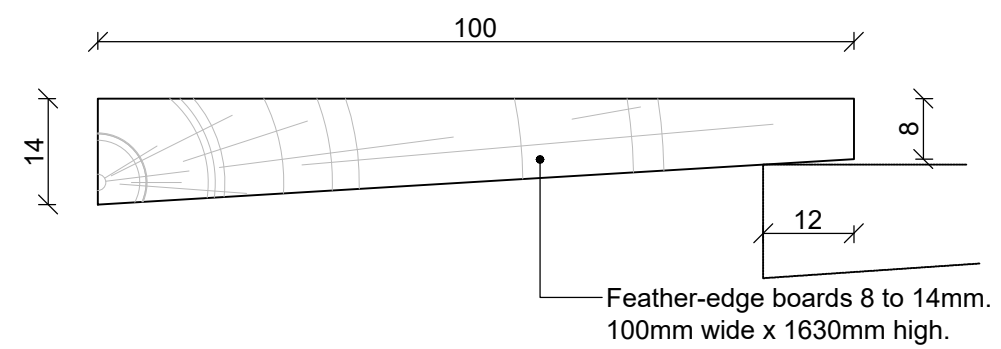

NOTES

Posts to be set in holes 300 x 300 x 600 or 800 or 750mm deep and bedded in weak concrete for half their depth below ground level, and remaining depth to be filled with rammed earth.

Posts should be weathered approx. 30 degrees from the horizontal leaving a flat approx. 38mm wide.

Boards should be minimum 100mm wide x 14mm to 8mm nailed to each rail and should lap 12mm min.

Nails: Galv. nails should be used throughout to avoid rust staining on the timber.

Posts to be softwood and to be pretreated with preservative.

Boarding to be softwood pretreated with preservative.

Posts and Fence in accordance with B.S. 1722 pt 5.

REV.	DESCRIPTION	DATE
CLIENT		
Engie Group		
DRAWING TITLE		
External Details		
1800mm High Treated Close Board Fence		
SCALE	DATE	DRAWN BY
1:20/1:5@A3	March '19	HA Ltd
DRAWING NO.	REVISION	TYPE
1839-D03		PLN



10 Gold Tops
Newport
NP20 4PH
t. 01633 844970
e. info@hammond-ltd.co.uk

www.hammond-ltd.co.uk

© Hammond Architectural Limited 2017
Figured dimensions must be taken in preference to scaled dimensions and any discrepancies are to be referred to Hammond Architectural Ltd. Contractors, subcontractors and suppliers must verify all dimensions on site before commencing any work or making any workshop drawings.